

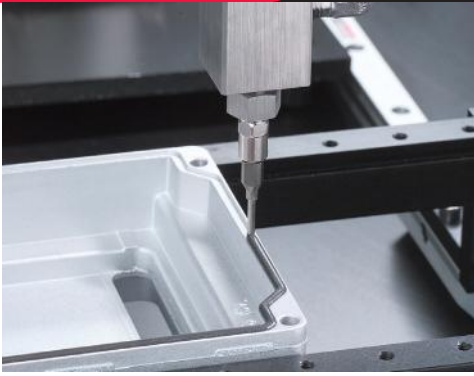

PVA

**WHERE
PRECISION
DRIVES
PRODUCTION**



VALVE SPECIFICATIONS

Dimensions

201 mm x 29.21 mm x 29.21 mm
(7.9 in x 1.15 in x 1.15 in)

Weight

19 oz.

Viscosity Range

1 cps – Paste

Operating Air Pressure:

60 – 100 psi

Maximum Inlet Fluid Pressure:

3500 psi

Wetted Components

Stainless steel, Viton, Carbide, Teflon®

FC300-C

Stainless Steel/Carbide Needle Valve

The FC300-C is a versatile high flow dispensing valve for any single component bead, dot, potting, or encapsulation project. Featuring a lightweight, compact design, the FC300-C is perfect for both automated and handheld processes in which a high volume of material is dispensed.

The FC300-C has many integrated features including:

- Divorced valve design prevents material contamination of the air section
- Carbide wetted parts for reliable processing of filled materials
- Stainless steel fluid body for superior material compatibility
- 1/4" NPT fluid port allows higher flow rates
- Adjustable flow control
- Spring-assisted valve closure for reliable cycle stops
- Compatible with all Luer-Lok™ needle tips

For more information on PVA's dispensing capabilities, please contact one of our sales representatives at (518) 371-2684.

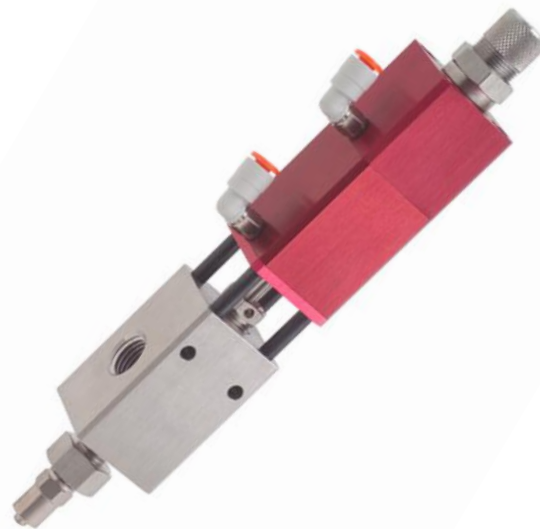

FC300-C Mounting Dimensions

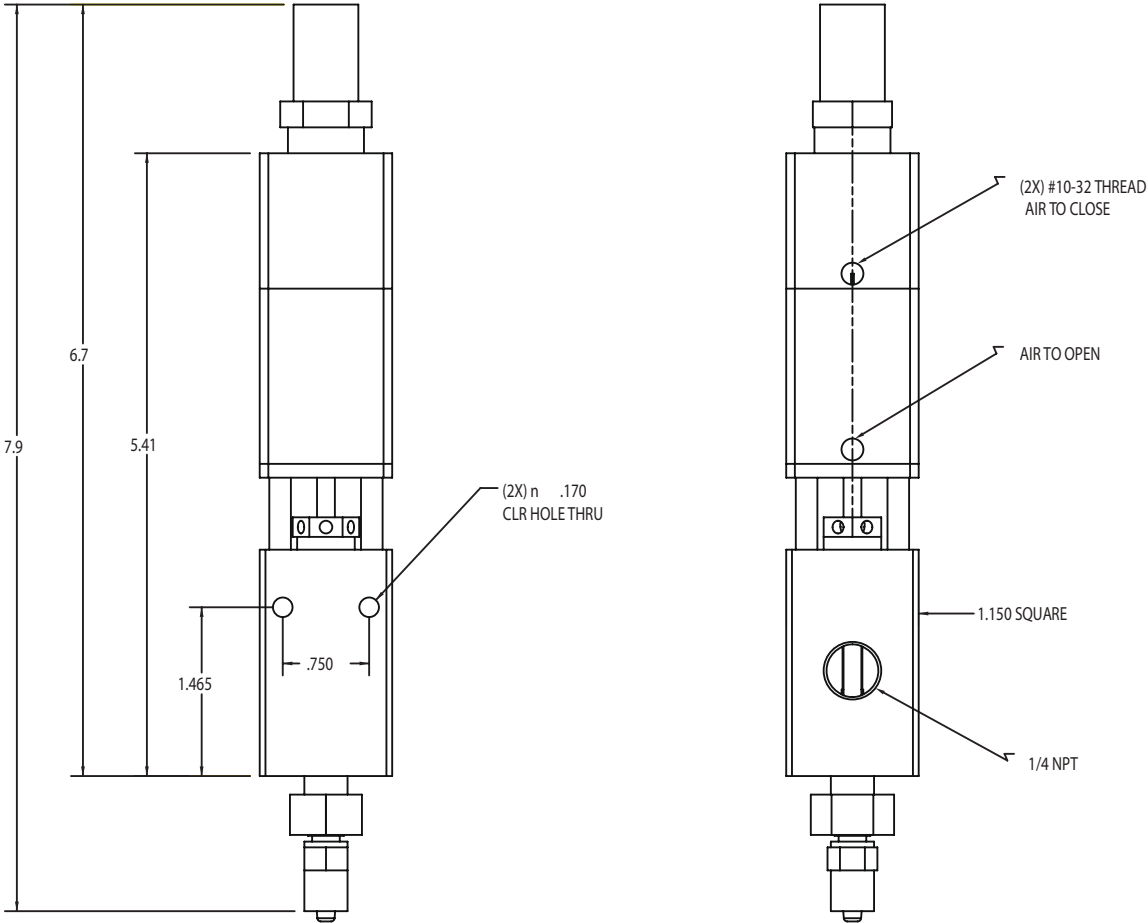

All dimensions provided in inches