

RC200

RADIAL COAT VALVE

Version: 112-3616

Operation Manual



**6 CORPORATE DRIVE
HALFMOON, NY 12065
PHONE: 518-371-2684
FAX: 518-371-2688**

info@pva.net

www.pva.net

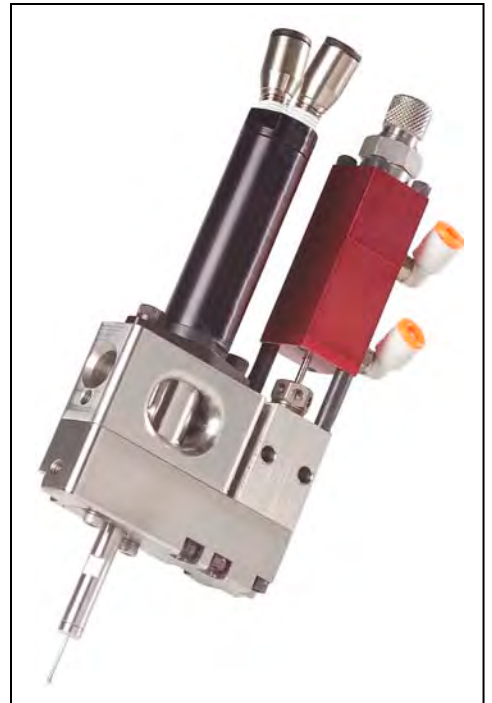

RC200

Front Closing Radial Coat Valve

Thank you for purchasing the RC200 dispensing valve from PVA. Before attempting to operate the RC200, we recommend that you take a few minutes and read the following operation and setup manual. This will assist in familiarizing you with the product and ensure a successful installation.

As always, if any questions or problems arise, do not hesitate to contact PVA's Valve Service Department for support. This department can be reached at PVA headquarters via telephone or e-mail.

Again, thank you for your purchase, and we look forward to assisting you in the future as you continue to improve your dispensing processes.

Theory of Operation

The RC200 is designed to spray low viscosity fluids onto the inside walls of a cylinder at a 90' degree angle to where it was inserted. A front closing valve section controls the start and stop of fluid while an air motor spins the nozzle at high rates to spray the coating using centrifugal force onto the inside diameter of a cylinder.

The RC200 is comprised of two major sections. These include:

- 1) FC100-Module, Front closing valve section
- 2) Rotary Fluid Section with air motor

The FC100-Module section consists of an aluminum body with a simple piston/cylinder combination used to open and close the valve with a stroke adjustment to regulate flow. The fluid portion of this valve section includes a needle and seat combination to start and stop the flow of coating.

The rotary portion of the fluid section contains a custom piston that allows fluid to flow to the end where custom designed, interchangeable nozzles can be attached. The custom designed nozzles will be made to fit certain diameter cylinders and contain a specific nozzle orifice for determining coating thickness. As the valve opens to allow fluid flow, the air motor will trigger on and spin the nozzle which will use centrifugal force to apply coating to the inside diameter of the cylinder. Fluids typically include but are not limited to low viscosity lubricants, coatings, solvents, water, etc.

Wetted parts on the RC200 include:

- 303, 304 stainless steel
- Teflon
- Kalrez

Safety

Due to material contents being under pressure eye protection is required for operators. Refer to MSDS sheets on material being dispensed for other precautions.

Setup

The RC200 requires a 2-position, 4-way air solenoid valve to actuate the air section to open and close the valve. A precision air regulator and oil lubricator will be connected in line to simultaneously activate the air motor. The valve should be operated with clean, dry air between 60-100psi. Two #10-32 threaded air ports are located on the air section of the FC100-Module and two 1/8"mnpt ports located on the air motor. The port located furthest from the midsection of the FC100-Module is air to close the valve. The port located closest to the mid-section of the FC100-Module is air to open the valve. The air motor is marked with a forward and reverse control port to determine the direction of rotation. Quick connect air fittings are typically supplied with the FC100 Module to fit 5/32" tubing while quick connect air fittings are supplied with the air motor to fit 1/4"od tubing. Note that the valve should be normally in the closed position.

Fluid is supplied to the RC200 valve through the 1/8"npt port located on the stainless steel fluid section of the valve.

The muffler of the air motor should be run a distance several feet from the valve to reduce noise in the work area. A small amount of air motor lubricant will be exhausted from the muffler.

Single Solenoid

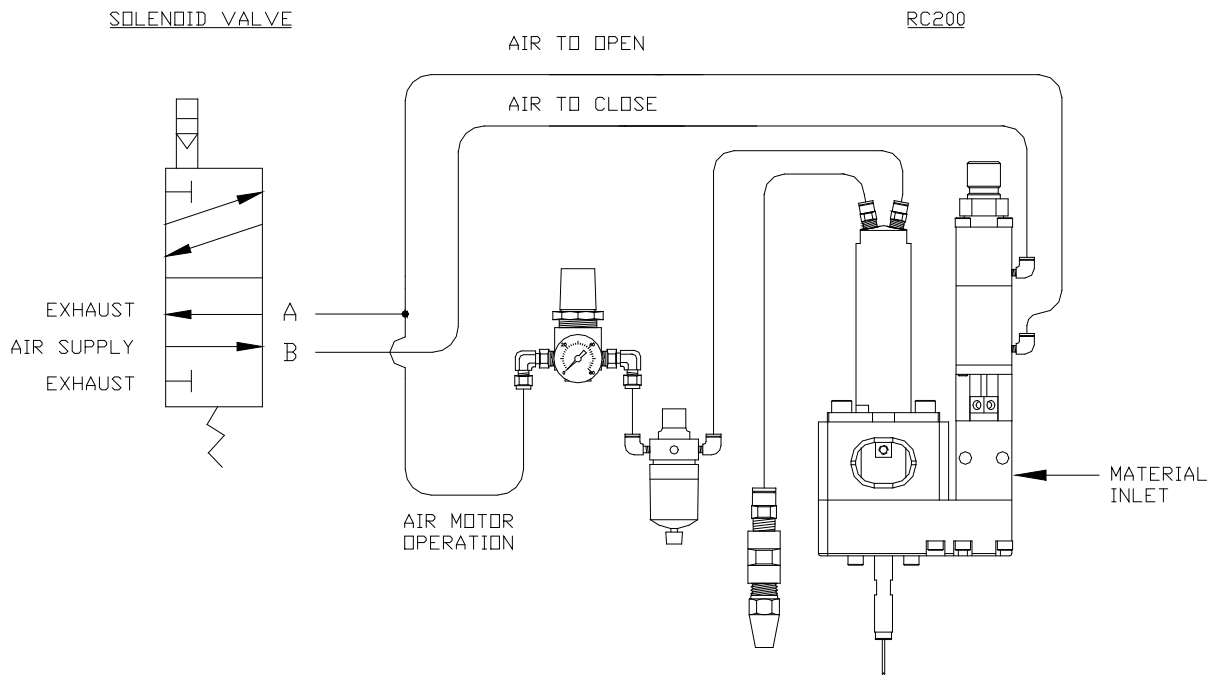

Dual Solenoid

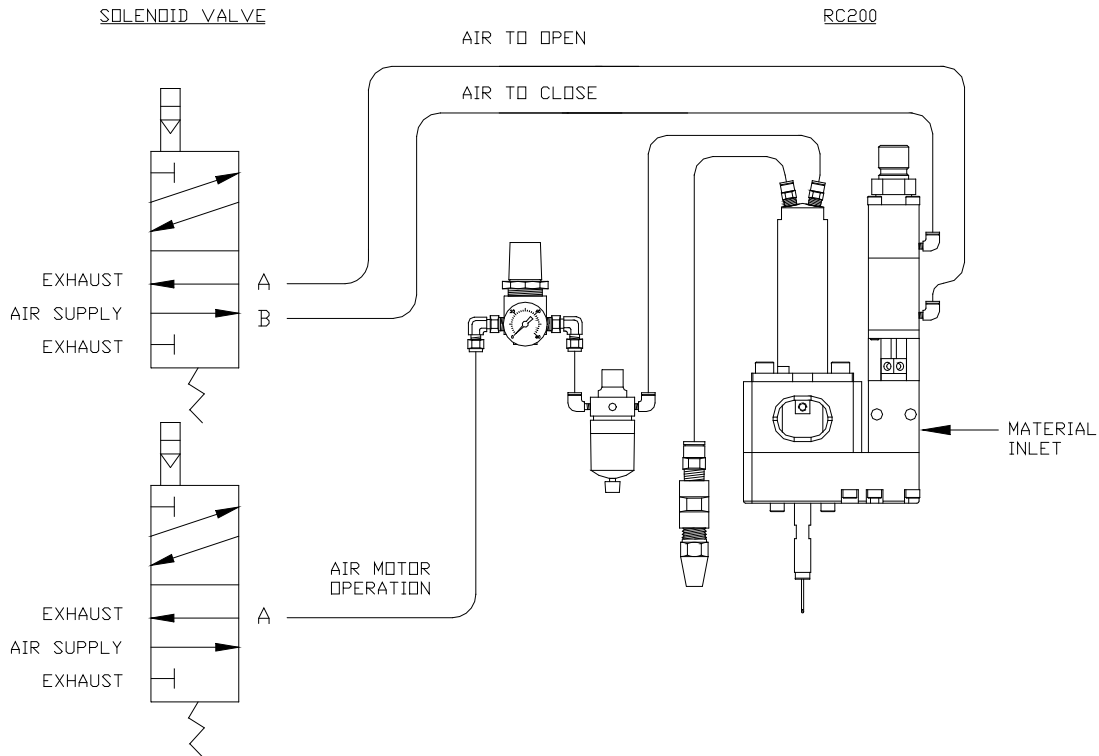

Tool Kit

PVA offers standard tool kits for all dispensing valves. The tool kit for the RC200 is part number **B12-2866**, which includes all necessary tools and lubricating grease to perform maintenance on this dispense valve:

B12-2866 Includes:

| Qty | Part Number | Description |
|-----|-------------|-----------------------------------|
| 1 | 0266244 | 8" Adjustable Wrench |
| 1 | 26569 | 9/64" Allen Key |
| 2 | 26563 | 3/32" Allen Key |
| 1 | 26561 | 5/64" Allen Key |
| 1 | 26559 | 1/16" Allen Key |
| 2 | 0216173 | M7 Wrench |
| 1 | 5516A18 | Tweezers |
| 1 | B62-0752 | 2.5cc Mineral Oil Lubrication Kit |
| 1 | B62-2048 | 2.5cc Silicone Lubricant |
| 1 | 27001 | Lubricant for Air Motor |
| 1 | 9570K71 | Hook and Pick Set |
| 1 | 0266255 | Pliers |
| 2 | 53085A61 | Soft Plastic Covers for Pliers |
| 1 | MM115 | Removable Thread Locker |

Operation

Refer to assembly drawings **112-2998 & 112-3616** for part reference numbers.

- 1) Plumb up the valve as outlined above in the **Setup** procedures.
- 2) Fill the air motor lubricator with oil (27001) provided with the valve.
- 3) Regulate the air pressure operating the FC100-Module portion of the valve between 60-100psi.
- 4) Making sure that the coating nozzle is inserted into a protective cylinder, cycle the valve several times. When the valve is cycling, the needle (1A) can be seen going up and down in the center and the air motor will be spinning the rotary shaft (3). If the air motor is not spinning, increase the air pressure until it begins to turn. The air motor typically requires a minimum of 20 psi in order to start spinning.
- 5) Again, cycle the valve several times to ensure the valve is opening and the air motor is spinning with each cycle.
Note: If the valve is not cycling properly, refer to the **Troubleshooting** section.
- 6) When the fluid delivery system is connected to the valve, pressurize the material to be dispensed. The suggested starting pressure range is less than 5 psi.
- 7) Again, insert the nozzle of the valve into a protective cylinder in order to contain the material that will be sprayed.
- 8) Once again, cycle the valve open to purge. Fluid should begin to spray in a 360° degree pattern from the output of the coating nozzle.
- 9) Check the fluid connection and packing nut (16A) for leaks. If the valve is leaking, refer to the **Troubleshooting** section.
- 10) Adjust the fluid pressure in order to control the rate of fluid flow to the spray nozzle.
- 11) The stroke adjustment (12A) can also be used to fine tune the fluid flow. Turning the adjustment clockwise will decrease the material flow rate and counter-clockwise will increase the material flow rate. If the stroke adjustment bolt is turned all the way down it will stop the flow of fluid entirely.
- 12) Once the stroke adjustment setting is determined, use the adjustable wrench to tighten the lock nut (11A) up against the upper air body (10A).

Note: Refer to **Troubleshooting** section for any problems.

Periodic Maintenance

- 1) Visually check the see through chamber of the air motor lubricator daily and refill when it runs empty.
- 2) Lubricate the packing (15A) on the FC100-Module every 200 hrs by placing a few drops of mineral oil or other light oil inside the packing nut.
*Note: PVA offers a 2.5cc mineral oil lubrication kit; Part#: B62-0752
- 3) The packing nut (16A) will require occasional tightening, as wear occurs in order to prevent leaks through the packing.

Air Motor Lubricator

The air motor must stay lubricated with a small amount of light oil in order to maintain a long usable life. An air motor lubricator and oil are supplied with the RC200 valve. The oil level can be seen through the clear chamber on the bottom section of the lubricator. When the oil runs out it will be necessary to refill the chamber. To do this simply unthread and remove the clear chamber to separate the sections. These parts should separate easily. Once removed, fill the clear chamber about half way with air motor oil and thread the chamber back onto the housing, hand tight.

*Note: PVA offers additional tubes of air motor oil; [Part#: 27001](#)

*Note: During this operation, be sure air pressure is removed from system.

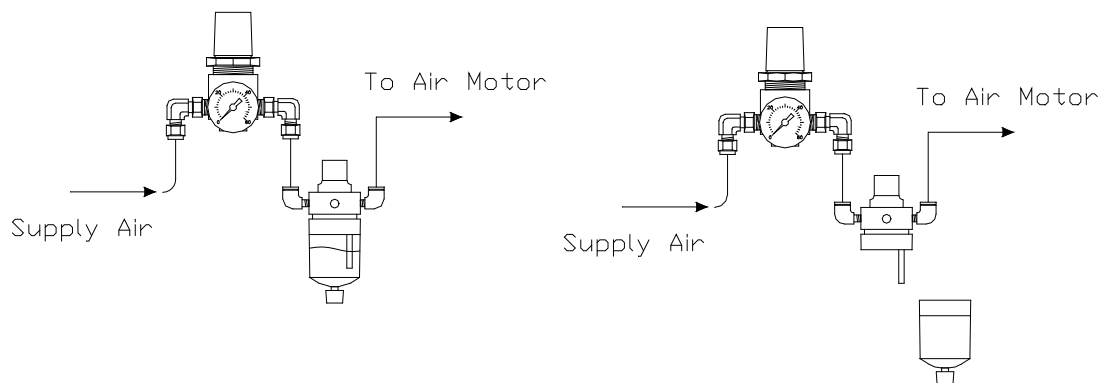

Routine Cleaning and Disassembly

Cleaning and rebuilding the valve will be required from time to time. A spare parts kit, part # **RC2-SP** is available with all the normal wear parts included.

- 1) Begin disassembly by removing air and fluid pressure from the valve.
- 2) Remove all pneumatic tubing and fluid delivery fittings, hoses, etc. from the valve.
- 3) To remove the coating nozzle (2), place the M7 wrench on the flat of the rotary shaft (3) and use the pliers to grab the coating nozzle, turning counter-clockwise to remove.
- 4) Using the 3/32" Allen Key, unthread and remove the four machine screws (9) that connect the FC100-Module to the fluid section of the RC200.
- 5) On the FC100-Module use the 3/32" Allen key to loosen the packing nut (16A).
- 6) Using the same 3/32" Allen key, evenly remove the two machine screws (3A) that are located on the same corners as the standoffs (6A). Note during removal that there is a spring (5A) forcing the air section away from the fluid section.
- 7) Pull the air section (red anodized portion) away from the fluid section (stainless steel portion).
- 8) Clean off the tip of the stainless steel needle (1A).

- 9) From the stainless steel fluid section of the valve, unthread and remove the packing nut (16A), and the packing (15A).
- 10) Using the pliers pull the seat (13A) out of the fluid section (14A) and remove the 006 Kalrez o-ring (18A) from the seat. Note: If stuck, the seat can be pushed through from the opposite side of the fluid section.
- 11) Clean all of the wetted parts thoroughly with an appropriate solvent.
- 12) On the air section, use a standard 3/32" Allen Key to evenly remove the final two machine screws (2A) that thread into the end cap (7A). Note: During removal that the spring (5A) will force the air section apart.
- 13) Separate the upper air body (10A) from the lower air body (8A) to remove the spring (5A) then slide the end cap (A) off of the needle (1A).
- 14) Holding the lower air body (8A) in one hand, grab the needle (1A) and push the needle and piston (9A) assembly out of the lower air body.
- 15) Remove the 004 Buna o-ring (17A) from the lower air body (8A).
- 16) Hold the piston (9A) with an adjustable wrench then use a 5/64" Allen key to unthread and remove the set screw (4A) to remove the needle (1A) then remove the 014 Buna o-ring (20A) from the piston (9A).
- 17) Remove the 014 Buna o-ring (20A) from the upper air body (10A) and the 008 Buna o-ring from the stroke adjust bolt (12A).
- 18) Unthread the stroke adjust bolt (12A) from the upper air body (10A) and remove the 008 Buna o-ring (12A).
- 19) On the fluid body (4) of the RC200 remove the 010 Kalrez o-ring (12) that sealed against the FC100-Module.
- 20) Using the 3/32" Allen Key, remove the plug (11) from the fluid body (4).
- 21) Using the 1/16" Allen Key, loosen the set screw on the rotary shaft (3).
- 22) To remove the air motor (7) use the 9/64" Allen key to unthread and remove the two machine screws (10) then slide the air motor away from the motor mount (5).
- 23) The rotary shaft (3) can now be pushed through the valve and removed through the motor mount (5).
- 24) Using the 3/32" Allen Key, remove the two machine screws (9) that secure the motor mount (5) to the fluid body (4) and separate the two sections to remove the 010 Kalrez o-ring (12).
- 25) Using the same 3/32" Allen Key, remove the two machine screws (8) that secure the seal plate (6) to the fluid body (4) and separate the two sections to remove the final 010 Kalrez O-Ring (12).

- Replace components with spares provided in the spare parts kit.

Assembly Instructions

General

- All o-rings must be lubricated with a small amount of silicone grease.
- A small amount of removable thread locker should be applied to the set screw (4A) and the male thread of the standoffs (6).
- Assemble the air section of the FC100-Module and fluid section separately prior to connecting the two assemblies.

Air Section

- 1) Assemble the stroke adjust (12A) and lock nut (11A) with the hex head toward the knurled end of the bolt.
- 2) Mount one 008 Buna o-ring (19A) on the inside groove of the stroke adjust (12A).
- 3) Thread the stroke adjustment assembly into the upper air body (10A).
- 4) Mount one 014 Buna o-ring (20A) on the end of the upper air body (10A) and the other 008 Buna o-ring (19A) on the end groove of the stroke adjust (12A). Back out the stroke adjust by turning it counter clockwise to the end of its travel.
- 5) Drop the needle (1A) into the piston (9A) and assemble with the set screw (4A) using an adjustable wrench and 5/64" Allen key to tighten.
- 6) Mount the 014 Buna o-ring (20A) onto the piston (9A).
- 7) Apply a small amount of silicone grease to the inside of the lower air body (8A) then drop in the piston and needle assembly.
- 8) Mount the 004 Buna o-ring (17A) on the end of the needle and slide it down into the groove in the end of the lower air body (8A).
- 9) Slide the end cap (7A) onto the needle up to the lower air body (8A), place the spring (5A) on top of the piston (9A), and assemble the two air bodies using two machine screws (2A) tightening with a 3/32" Allen key.
*Note: Be sure the air holes are lined up on the same face and will align with the fluid inlet on the fluid section (14A).

Fluid Section

- 1) Place a 010 Kalrez O-ring (12) into the bottom of the fluid body (4) and follow on top of it with the seal plate (6).
 - 2) Secure the seal plate to the fluid body with two machine screws (8) using a 3/32" Allen Key to tighten.
 - 3) Place the second 010 Kalrez O-ring (12) into the top groove of the fluid body (4) and follow on top of that with the motor mount (5).
 - 4) Secure the motor mount to the fluid body with two machine screws (9) using a 3/32" Allen Key to tighten.
 - 5) Insert the small diameter end of the rotary shaft (3) into the motor mount (5) cavity and push it through until it bottoms out and the smaller diameter end is protruding through the seal plate (6).
 - 6) Place the air motor (7) onto the motor mount and assemble with two machine screws (10) using the 9/64" Allen Key to tighten.
 - 7) Rotate the rotary shaft (3) until the set screw is positioned on the flat of the air motor shaft (7) then use the 1/16" Allen key to tighten in place.
 - 8) Insert the plug (11) into the fluid body (4) and tighten using the 3/32" Allen key.
 - 9) Drop the packing (15A) into the fluid section (14A), and screw in the packing nut (16A) but leave finger tight until assembled with the air section.
 - 10) Mount the 006 Kalrez o-ring (18A) on the seat (13A) and push the seat into the bottom of the fluid section (14A). When inserting the seat, work the o-ring into the fluid body with finger to prevent shearing of the edge of the o-ring.
 - 11) Place the final 010 Kalrez O-ring (12) into the groove of the fluid body (4) then place the fluid section (14A) assembly on top of that and secure the assembly with the four machine screws (9) using the 3/32" Allen Key to tighten.
- *Note: Be sure the 1/8" npt fluid port is facing away from the air motor.

Assemble Sections

- 1) Back out the stroke adjust bolt (12A) by turning it counter clockwise until the end of its travel.
- 2) Apply a small amount of silicone grease to the end of the needle (1A) and insert it into the packing nut (16A) and slide the two sections together.
- 3) Align the air holes of the air section on the same face as the fluid inlet of the fluid section then connect the sections using the two machine screws (3A) tightening them down evenly using a 3/32" Allen key.
- 4) Using the tip of a 3/32" Allen key, tighten the packing nut (16A).

Spare Parts

PVA offers standard spare parts kits for all dispensing valves. These kits are stocked for immediate shipment and allow replacement of all wearable parts of the valve.

The spare parts kit for this valve, product number **RC2-SP**, includes the following components:

RC2-SP Includes:

| Qty | Part Number | Description |
|------------|--------------------|--------------------|
| 1 | V302 | Seat |
| 1 | 114-5247 | Needle |
| 1 | V305 | Packing, Teflon |
| 2 | VLV-014B | O-ring, Buna |
| 2 | VLV-008B | O-ring, Buna |
| 1 | VLV-006K | O-ring, Kalrez |
| 1 | VLV-004B | O-ring, Buna |
| 3 | VLV-010K | O-Ring, Kalrez |

SECTION A-A

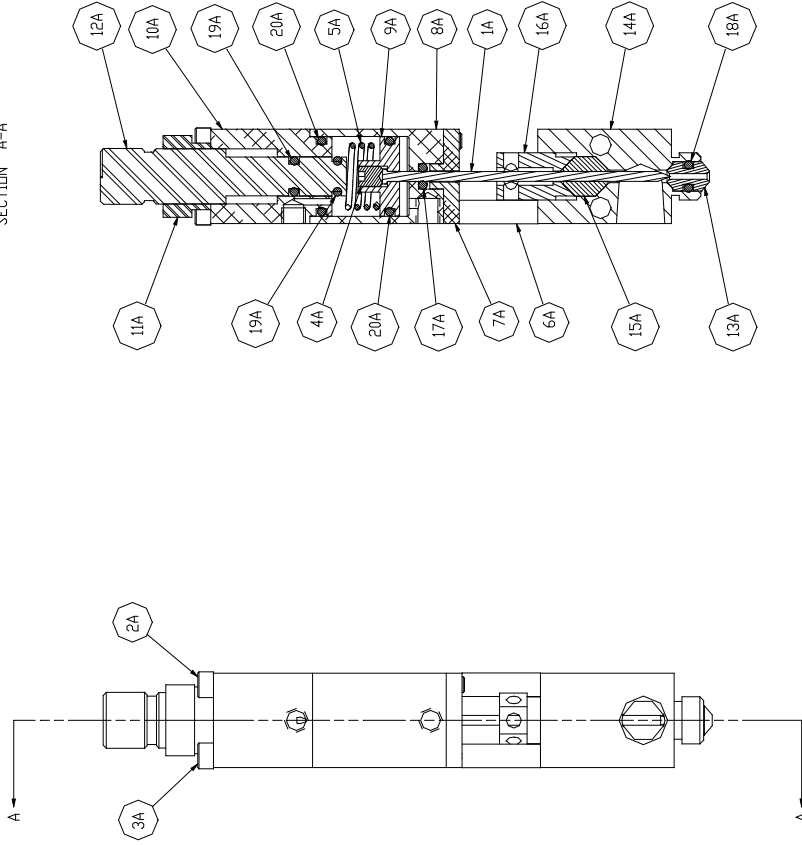

| REV | REVISION DESCRIPTION | DRN BY | DATE | DESIGN REV | REVISION DESCRIPTION | DRN BY | DATE | DESIGN | UNLESS OTHERWISE SPECIFIED DIMENSIONS ARE IN INCHES DECIMALS AND FRACTIONS XXX.X XXX X.X X.XX X.XX X.XXX X.XXX X.XXXX X.XXXX X.XXXXX | MATERIAL: |
|---|----------------------|--------|---------|------------|----------------------|--------|------|--------|---|-----------|
| A | ORIGINAL DESIGN | DER | 23MAY11 | RJB | | | | | | PVA |
| | | | | | | | | | | FINISH: |
| | | | | | | | | | | ▽ |
| <p>THIS DOCUMENT, INCLUDING THE INFORMATION CONTAINED HEREIN, IS THE PROPERTY OF PRECISION VALVE & AUTOMATION, INC. AND IS CONSIDERED CONFIDENTIAL AND PROPRIETARY INFORMATION. IT IS DELIVERED ON THE EXPRESS CONDITION THAT IT NOT BE USED, DISCLOSED, OR REPRODUCED IN WHOLE OR IN PART, FOR ANY REASON WITHOUT PRIOR WRITTEN CONSENT OF PRECISION VALVE & AUTOMATION INC.</p> | | | | | | | | | | |
| <p>TITLE: FC100 MODULE DWG#: 112-2998</p> | | | | | | | | | | |
| <p>QTY: -</p> | | | | | | | | | | |
| <p>SHEET: 2 OF 2</p> | | | | | | | | | | |
| <p>REV: A</p> | | | | | | | | | | |

BILL OF MATERIALS FOR: FC100-MODULE (112-2998):

| Item | Part Number | Description | Quantity |
|-------------|--------------------|-----------------------|-----------------|
| 1A | 114-5247 | Needle | 1 |
| 2A | SH5-40 x 2.0 | Socket Head Cap Screw | 2 |
| 3A | SH5-40 x 2.25 | Socket Head Cap Screw | 2 |
| 4A | V001 | Set Screw | 1 |
| 5A | V050 | Spring | 1 |
| 6A | V075 | Standoff | 2 |
| 7A | V200 | End Cap | 1 |
| 8A | V201 | Lower Air Body | 1 |
| 9A | V202 | Piston | 1 |
| 10A | V228 | Upper Air Body | 1 |
| 11A | V229 | Lock Nut | 1 |
| 12A | V230 | Stroke Adjust | 1 |
| 13A | V302 | Seat | 1 |
| 14A | V304PC | Fluid Section | 1 |
| 15A | V305 | Packing | 1 |
| 16A | V306 | Packing Nut | 1 |
| 17A | VLV-004B | Buna O-Ring | 1 |
| 18A | VLV-006K | Kalrez O-Ring | 1 |
| 19A | VLV-008B | Buna O-Ring | 2 |
| 20A | VLV-014B | Buna O-Ring | 2 |

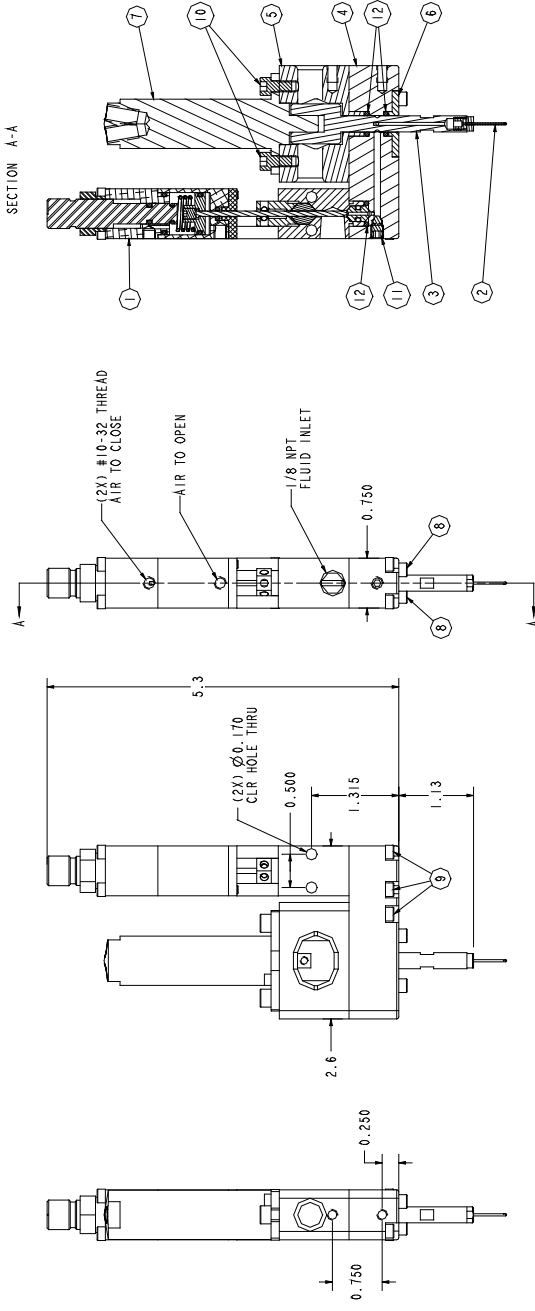

| REV | REVISION DESCRIPTION | DRN BY | DATE | DESIGN REV | REVISION DESCRIPTION | DRN BY | DATE | DESIGN | MATERIAL: |
|-----|----------------------|--------|---------|------------|----------------------|--------|------|--------|----------------|
| A | ORIGINAL DESIGN | DER | 27MAY10 | RJB | | | | | PVA |
| | | | | | | | | | TITLE: RC200 |
| | | | | | | | | | FINISH: |
| | | | | | | | | | DWG#: 112-3616 |
| | | | | | | | | | QTY: - |
| | | | | | | | | | SHEET: 1 OF 1 |
| | | | | | | | | | REV: A |

This document, including the information contained herein, is the property of PRECISION VALVE & AUTOMATION, Inc. and is considered confidential and proprietary information. It is to be used only for the specific project and under the express condition that it not be used, disclosed, or reproduced in whole or in part, for any reason without prior written consent of PRECISION VALVE & AUTOMATION, Inc.

BILL OF MATERIALS FOR: RC200 (112-3616):

| Item | Part Number | Description | Quantity |
|-------------|--------------------|-----------------------|-----------------|
| 1 | 112-2998 | FC100 Module | 1 |
| 2 | 112-3295 | Nozzle Assembly | 1 |
| 3 | 214-0934 | Rotary Shaft | 1 |
| 4 | 214-0935 | Fluid Body | 1 |
| 5 | 214-0937 | Motor Mount | 1 |
| 6 | 214-0944 | Seal Plate | 1 |
| 7 | MMR-0700 | Air Motor | 1 |
| 8 | SH5-40x0.250 | Socket Head Cap Screw | 2 |
| 9 | SH5-40x0.750 | Socket Head Cap Screw | 6 |
| 10 | SH8-32x0.3125 | Socket Head Cap Screw | 2 |
| 11 | V007 | Plug | 1 |
| 12 | VLV-010K | O-Ring, Kalrez | 3 |

Troubleshooting

| Problem | Possible Cause | Corrective Action |
|-------------------------------|--|--|
| Valve does not cycle | <ul style="list-style-type: none"> - Air pressure to air section too low - Packing nut is too tight - Stroke adjustment is bottomed out - Material is cured in the valve - Valve was assembled w/o lubricating the O-ring seals | <ul style="list-style-type: none"> - Increase air pressure to 60-100 psi - Loosen packing nut until valve just begins to cycle, retighten - Back out stroke adjustment by turning it counter-clockwise - Disassemble and clean valve - Disassemble valve, lubricate seals and re-assemble |
| Material leaks from valve tip | <ul style="list-style-type: none"> - Packing nut is too tight - Needle and/or seat are worn | <ul style="list-style-type: none"> - Loosen packing nut - Replace parts as necessary |
| Valve leaks from packing | <ul style="list-style-type: none"> - Packing nut is loose - Packing is worn | <ul style="list-style-type: none"> - Tighten packing nut until snug - Replace packing |
| Valve leaks from motor-mount | <ul style="list-style-type: none"> - O-rings on rotary shaft are loose | <ul style="list-style-type: none"> - Replace O-rings |
| Valve does not spray anything | <ul style="list-style-type: none"> - Fluid pressure is too low - Material cured in fluid section or coating nozzle - Stroke adjustment is set too low | <ul style="list-style-type: none"> - Increase fluid pressure - Disassemble valve and clean - Back out stroke adjustment by turning it counter-clockwise |
| Spray rate too fast | <ul style="list-style-type: none"> - Stroke adjustment set out too far - Fluid pressure too high - Spray nozzle too large | <ul style="list-style-type: none"> - Turn stroke adjustment clockwise - Decrease fluid pressure - Contact PVA for smaller nozzle |
| Spray rate too slow | <ul style="list-style-type: none"> - Stroke adjustment set too low - Fluid Pressure too high - Spray nozzle too small | <ul style="list-style-type: none"> - Turn stroke adjustment counter-clockwise - Increase fluid pressure - Contact PVA for large nozzle |
| Air motor does not spin | <ul style="list-style-type: none"> - Air pressure to motor set too low - No lubrication on air motor | <ul style="list-style-type: none"> - Increase air pressure to motor - Refill air motor lubricator chamber |

PVA Warranty Policy

PVA warrants the enclosed product against defects in material or workmanship on all components for one year from the date of shipment.

The warranty does not extend to components damaged due to misuse, negligence, or installation and operation that is not in accordance with the recommended factory instructions. Unauthorized repair or modification of the enclosed product, and/or the use of spare parts not directly obtained from PVA (or from factory authorized dealers) will void all warranties.

All PVA warranties extend only to the original purchaser. Third party warranty claims will not be honored at any time.

Prior to returning a product for a warranty claim, a return authorization must be obtained from PVA's customer service department. Authorization will be issued either via the telephone, facsimile, or in writing upon your request.

To qualify as a valid warranty claim, the defective product must be returned to the factory during the warranty period. Upon return, PVA will repair (or replace) all components found to be defective in material or workmanship.

(Retain this for your records)

Product Information:

PRODUCT: _____

SERIAL NUMBER: _____

DATE OF PURCHASE: _____